

PAX Water Mixer (PWM100) Product Specifications

Active Vortex Mixer for Small Water Tanks

- 3x mixing power vs. sheet mixers
- Easy install, self-righting design
- Prevents ice formation
- Eliminates thermal stratification
- Improves disinfectant residual levels
- Lowers DBPs and nitrifying bacteria
- 3-year warranty

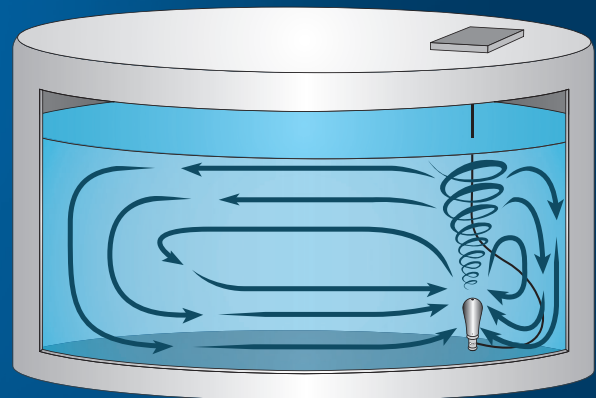

PAX Water Mixer vigorously circulates the entire tank volume.

Find out how a PAX Water Mixer can help you.
Call our Water Quality Specialists today at **1-866-729-6493**
or visit **www.paxwater.com**

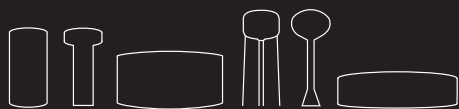

PAX Water Mixer (PWM100)

Product Specifications

The PAX Water Mixer (PWM100) is an active vortex mixer for small water storage tanks. Patented PAX technology provides the most powerful small tank mixing to thoroughly circulate the entire tank volume. The mixer installs easily and self-rights at the bottom of a tank, even on a sloped floor.

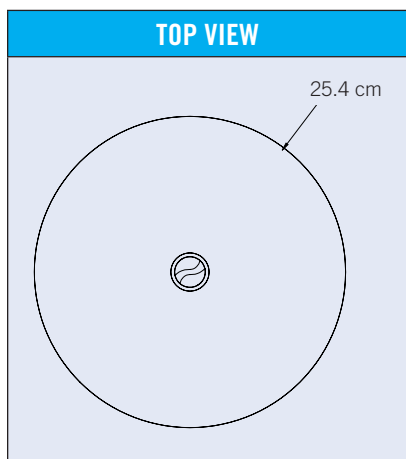
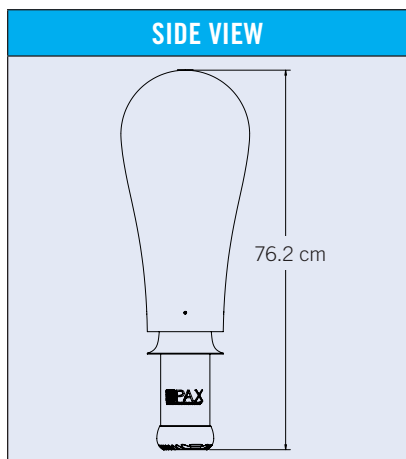

MIXER SPECIFICATIONS	
Power Supply Requirement	230 VAC, 50 Hz, GFCI-protected, 20 amp circuit
Customer Supplied Power Switch	3R fused, safety disconnect switch
Motor Type	230 VAC, 50 Hz, water-filled, water-lubricated
Nominal Power Draw	1.32 kVA (1320 watts)
Footprint Diameter	25.4 cm
Height	76.2 cm
Weight	18.1 kg
Material: Housing	316 stainless steel
Material: Motor Seals	Chlorine/chloramine-resistant NBR rubber
Material: Foot	Chlorine/chloramine-resistant EPDM rubber
Wiring	NSF 61 & UL-listed submersible pump cable 2.1 mm ² XLPE



Certified to NSF/ANSI 61-G



P.O. Box 1093, Croydon, 3136, Australia.
Tel: (03) 9761 4000 Fax: (03) 9761 4006
EMAIL: controls@metaval.com.au

Suppliers of Process Equipment

Find out how a PAX Water Mixer can help you.
Call our Water Quality Specialists today at **1-866-729-6493**
or visit **www.paxwater.com**

