

Models 106-PR-R / 206-PR-R

Pressure Reducing and Pressure Sustaining Valve



106-PR-R Globe

KEY FEATURES

- Excellent low flow stability
- Ensures minimum upstream pressure
- Easily and precisely set downstream pressure

Product Overview

The 106-PR-R and 206-PR-R pressure reducing and pressure sustaining valves are based on the 106-PG or 206-PG main valve with the addition of the sustaining pilot 81-RP and pressure reducing pilot PR-160.

Provided the upstream pressure setting is satisfied, the 81-RP pilot is kept open, permitting the valve to be controlled by the 160 pilot. The 160 pilot senses downstream pressure and under flowing conditions, it reacts to small changes in pressure to control the valve position by modulating the pressure above the diaphragm.

Should high demand cause the inlet pressure to fall to the 81-RP pilot setting, the upstream pressure has priority and the valve will modulate to prevent the upstream pressures from dropping below the set-point.

When the valve is modulating to sustain upstream pressure above the minimum 81-RP pilot set-point, the downstream 160 pilot may try to open the valve to maintain its set-point, but upstream has priority and downstream pressures will fall below expectations.

In typical applications, the reduced port model 206-PR-R is often the best selection.

Models 106-PR-R / 206-PR-R Pressure Reducing and Pressure Sustaining Valve

Typical Application

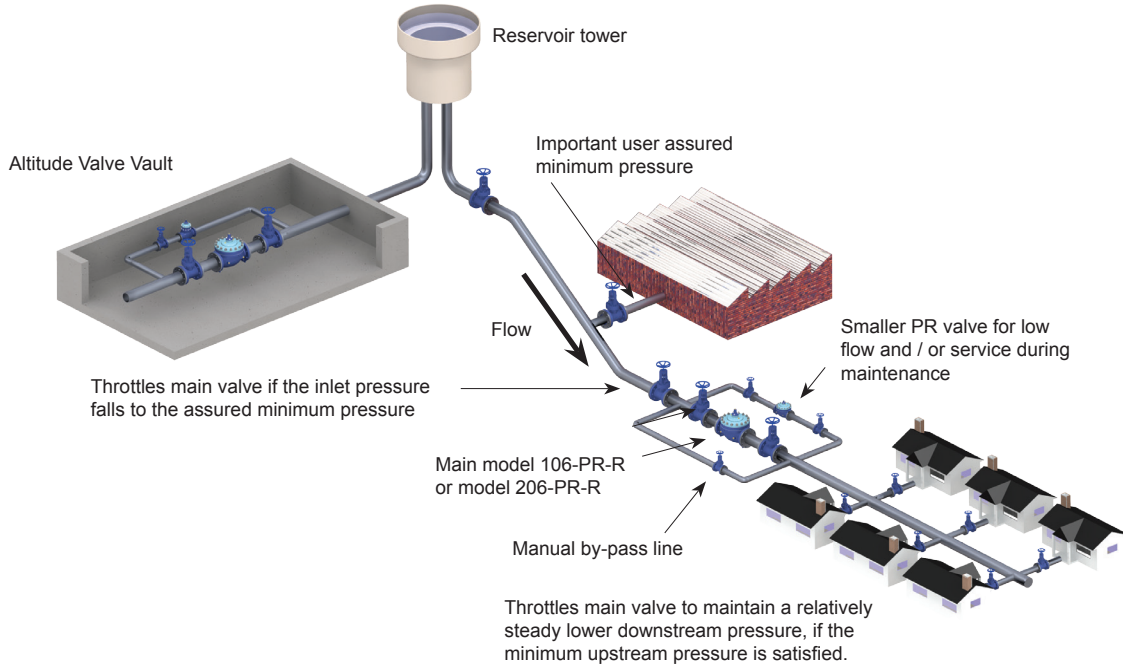

Schematic Drawing

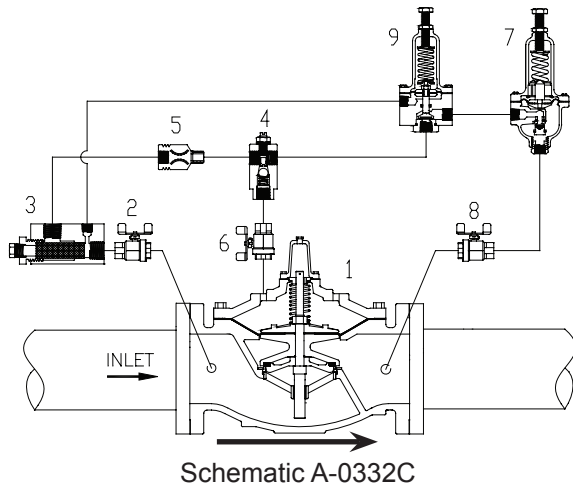

1. Main Valve - 106-PG or 206-PG
2. Isolation Valve - standard 4 in / 100 mm and larger
3. Strainer - standard 4 in / 100 mm and larger
4. Model 26 Flow Stabilizer / Opening Speed Control
 - Standard (106 or 206) on flat diaphragm valves
 - Optional on rolling (S106 or S206) diaphragm valves
5. Fixed Restriction
6. Isolation Valve - standard 4 in / 100 mm and larger
7. Model 160 pilot
 - Specify for 5 to 50 psi / 0.35 to 3.5 bar,
 - 10 to 80 psi / 0.70 to 5.5 bar,
 - 20 to 200 psi / 1.3 to 13.8 bar,
 - 100 to 300 psi / 6.9 to 20.7 bar.
8. Isolation Valve - standard all sizes
9. Model 81-RP pilot
 - specify for 5 to 50 psi / 0.35 to 3.5 bar, 10 to 80 psi / 0.7 to 5.5 bar, 100 to 300 psi / 6.9 to 20.7 bar.

Standard Materials

Standard materials for pilot system components are:

- ASTM B62 bronze or ASTM B16 brass
- AISI 303/316 stainless trim

Models 106-PR-R / 206-PR-R

Pressure Reducing and Pressure Sustaining Valve

Specifications

- The valve shall be a Singer Valve model 106-PR-R / 206-PR-R, size “_____”, ANSI Class 150 (ANSI 300, ANSI flanges drilled to ISO PN 10 / 16 / 25 or 40) pressure rating / flange standard, globe (angle), style valve. The Model 160 Pressure Reducing Pilot (Normally Open Pilot) spring range shall be “___ to ___” psi / “___ to ___” bar, with set-point preset at Singer Valve to “___” psi / “___” bar. The Model 81-RP Pressure Relief Pilot (Normally Closed Pilot) spring range shall be “___ to ___” psi / “___ to ___” bar, with set-point preset at Singer Valve to “___” psi / “___” bar. Assembly shall be according to Schematic A-0332C.
- The valve shall maintain relatively accurate control of the downstream pressure regardless of fluctuation in flow or upstream pressure until the upstream pressure drops to a pre-determined value. The sustaining pilot shall override the pressure reducing function at such time as the upstream pressure drops to the pre-determined value maintaining relatively steady upstream pressure.
- Refer to Main Valve section, page 11, 106-PG or 206-PG for detailed information pertaining to valve sizes and materials, selection criteria and specifications.
- Refer to Pilot and Accessories, page 249, section, Model 160 Pressure Reducing Pilot (Normally Open Pilot), Model 81-RP Pressure Relief Pilot (Normally Closed Pilot) and Model 26 Flow Stabilizer for detailed information pertaining to materials and specifications.

Selection Summary

1. Select the valve series and size with sufficient capacity
2. Check the operating flow against valve minimum.
3. If the outlet pressure is less than 35% of the inlet pressure, check for cavitation.
4. Ensure that the flange rating exceeds the maximum operating pressure.

Ordering Instructions

Refer to page 286 for the order form and ordering instructions.

Additionally, include the following information for this product:

1. Full port (106) or reduced port (206)
2. Pilot ranges

Models 106-PR-R / 206-PR-R

Pressure Reducing and Pressure Sustaining Valve

106-PR-R	Flow Capacity (See 106-PG in Main Valve section for other valve data)								
	1/2 in	3/4 in	1 in	1-1/4 in	1-1/2 in	2 in	2-1/2 in	3 in	4 in
Size (inches)	1/2 in	3/4 in	1 in	1-1/4 in	1-1/2 in	2 in	2-1/2 in	3 in	4 in
Size (mm)	15 mm	19 mm	25 mm	32 mm	40 mm	50 mm	65 mm	80 mm	100 mm
Minimum (USGPM) Flat Diaphragm	1	1	1	1	1	5	5	5	10
Minimum (L/s) Flat Diaphragm	0.1	0.1	0.1	0.1	0.1	0.3	0.3	0.3	0.6
Maximum Continuous (USGPM)	12	19	49	93	125	210	300	460	800
Maximum Continuous (L/s)	0.8	1	3	6	8	13	19	29	50

106-PR-R	Flow Capacity (See 106-PG in Main Valve section for other valve data)								
	6 in	8 in	10 in	12 in	14 in	16 in	20 in	24 in	36 in
Size (inches)	6 in	8 in	10 in	12 in	14 in	16 in	20 in	24 in	36 in
Size (mm)	150 mm	200 mm	250 mm	300 mm	350 mm	400 mm	500 mm	600 mm	900 mm
Minimum (USGPM) Flat Diaphragm	20	40	-	-	-	-	-	-	-
Minimum (USGPM) Rolling Diaphragm	1	1	3	3	3	3	10	10	20
Minimum (L/s) Flat Diaphragm	1.3	2.5	-	-	-	-	-	-	-
Minimum (L/s) Rolling Diaphragm	0.1	0.1	0.2	0.2	0.2	0.2	0.6	0.6	1.3
Maximum Continuous (USGPM)	1800	3100	4900	7000	8500	11000	17500	25800	55470
Maximum Continuous (L/s)	114	196	309	442	536	694	1104	1628	3500

206-PR-R	Flow Capacity (See 206-PG in Main Valve section for other valve data)								
	3 in	4 in	6 in	8 in	10 in	12 in	16 in	18 in	20 in
Size (inches)	3 in	4 in	6 in	8 in	10 in	12 in	16 in	18 in	20 in
Size (mm)	80 mm	100 mm	150 mm	200 mm	250 mm	300 mm	400 mm	450 mm	500 mm
Minimum (USGPM) Flat Diaphragm	5	5	10	20	40	-	-	-	-
Minimum (USGPM) Rolling Diaphragm	-	-	-	-	-	3	3	3	3
Minimum (L/s) Flat Diaphragm	0.3	0.3	0.6	1.3	2.5	-	-	-	-
Minimum (L/s) Rolling Diaphragm	-	-	-	-	-	0.2	0.2	0.2	0.2
Maximum Continuous (USGPM)	300	580	1025	2300	4100	6400	9230	16500	16500
Maximum Continuous (L/s)	19	37	65	145	260	404	582	1040	1040

206-PR-R	Flow Capacity (See 206-PG in Main Valve section for other valve data)					
	24 x 16 in	24 x 20 in	28 in	30 in	32 in	36 in
Size (inches)	24 x 16 in	24 x 20 in	28 in	30 in	32 in	36 in
Size (mm)	600 mm	600 mm	700 mm	750 mm	800 mm	900 mm
Minimum (USGPM) Rolling Diaphragm	3	3	10	10	10	10
Minimum (L/s) Rolling Diaphragm	0.2	0.2	0.6	0.6	0.6	0.6
Maximum Continuous (USGPM)	16500	21700	33600	33650	33700	33800
Maximum Continuous (L/s)	1040	1370	2120	2123	2126	2132